

# Deep Cleaning Reference Guide

## BARISTA 600 TOUCH



**Necta**

For more information and details,  
consult the Installation Manual.

Manufactured by:

Evoca North America Venture Inc.

2355, avenue Dalton, Québec (Québec) G1P 3S3 Canada

Tel.: 800-561-6162 | Fax: 800-463-2739

service.na@evocagroup.com | www.evocagroupna.com

*Images may vary from the actual product.*

Deep Cleaning Guide  
Barista 600 Touch  
2026-05



**PARTS ARE NOT  
DISHWASHER SAFE.**



**AIR DRY PARTS  
COMPLETELY BEFORE  
REINSTALLING THEM  
IN THE BREWER.**



To access Service Mode, press on the Necta logo on-screen during a few seconds. Factory setting PIN is 4444.



This is a reference guide for deep cleaning. For more information and details, consult the Installation Manual.

### **MATERIAL RECOMMENDED FOR DEEP CLEANING**

- Small brush
- Big brush
- Bucket (18L minimum)
- Scissors
- Towels
- Food-safe alkaline formula liquid cleaner for coffee and espresso equipment
- Food-safe cleaning and sanitizing spray
- Espresso machine cleaning tablet

### **COLOR CODED PARTS**

The Barista 600 Touch is color coded to help the operator know how to navigate the machine. All blue parts can be removed and all green parts can be moved to accomplish a necessary action.

# Weekly Cleaning Steps

1.

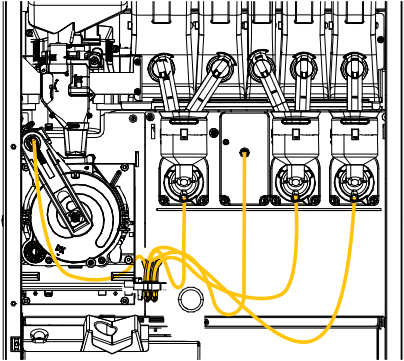

Unplug the 5 hoses from the mixers, the hot water funnel and the brew group then remove them. Take the hoses spout part out.

2.

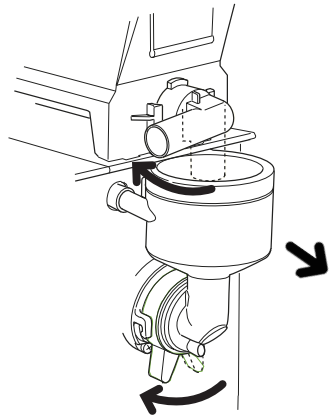

Remove all mixers by moving the canisters' spouts out of the way and rotating the ring nuts counterclockwise.

3.

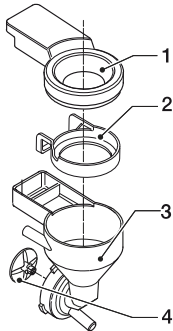

1. Powder funnel
2. Splash-guard ring
3. Water coveror
4. Mixer impeller

Remove the mixer impellers by pulling on them. Separate all mixers' components.

4.

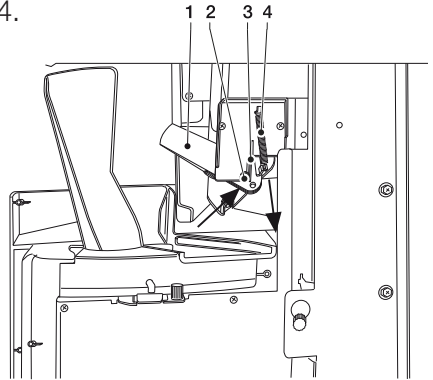

1. Sugar dispensing nozzle
2. Pin
3. Lever
4. Spring

Remove the sugar nozzle by lifting the lever, releasing the spring and extracting the pin.

## Weekly Cleaning Steps

5.

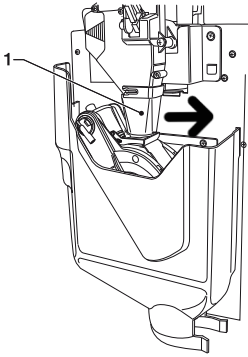

1. Coffee funnel

Remove the coffee funnel by sliding it to the right.

6.

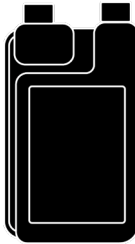

Fill a bucket (18L minimum) with 10L of hot water. Follow the instructions from the manufacturer of your food-safe alkaline formula liquid cleaner for coffee and espresso equipment.



**Water temperature in bucket must be between 140 °F and 176 °F (60 °C - 80 °C).**

7. Soak the previously removed following parts in the bucket. Brush them to remove all grime. Let them soak for at least 30 minutes.

- 5 hoses
- Hoses spout part
- 3 mixers (separated)
- Sugar spout
- Coffee funnel



**Use cleaning brushes to remove grime from each part. Insert them in tubes, part holes and corners.**

# Weekly Cleaning Steps

8.



While parts soak in the bucket, use your food-safe cleaning and sanitizing spray, a towel and the brushes to wipe clean the other parts by following the next steps.



**IMPORTANT**  
Rinse and air dry parts  
prior to reinstall in the  
brewer.

9.

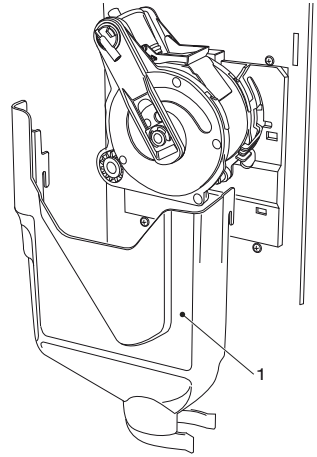

1. Brew group cover

Unhook and remove the brew group cover. Clean both sides. Rinse under hot water and air dry completely.

10.

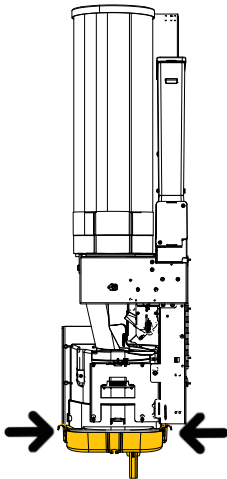

Remove the drip panel from beneath the dispensing area by unlocking it from each side. Clean, then rinse it under hot water. Air dry completely.

11.

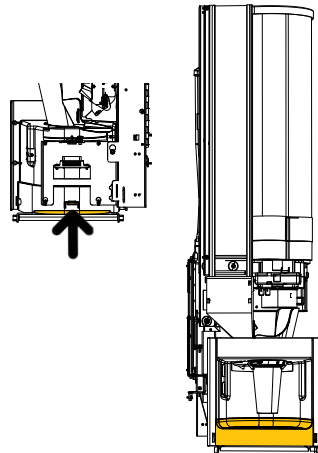

Unlock the drip tray from the back of the dispensing area, then remove it from the front. Clean, then rinse it under hot water. Air dry completely.

## Weekly Cleaning Steps

12.

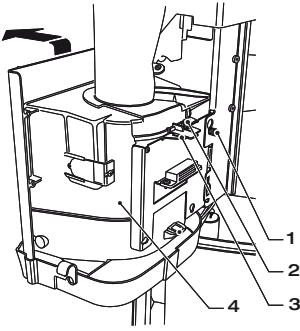

1. Dispensing compartment fastening knob
2. Cup chute fastening knob
3. Cup chute locking clip
4. Dispensing compartment

Remove the dispensing compartment from the back of the machine by unscrewing both fastening knobs and unclipping the cup chute. Clean it but pay special attention to the cup sensor area and the LED lights. Air dry completely.



### CHECKLIST

- Brew group cover
- Drip panel
- Drip tray
- Dispensing compartment



### IMPORTANT

**Rinse and air dry parts prior to reinstall in the brewer.**

13.



After at least 30 minutes, remove all soaked parts from the bucket. Rinse and air dry completely.



### IMPORTANT

**Rinse and air dry parts prior to reinstall in the brewer.**

14. Reinstall every part back in the brewer in the reverse order of removal.

**Weekly cleaning steps are done.**

# Monthly Cleaning Steps

1.

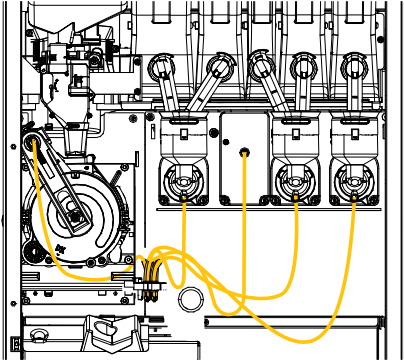

Unplug the 5 hoses from the mixers, the hot water funnel and the brew group then remove them. Take the hoses spout part out.

2.

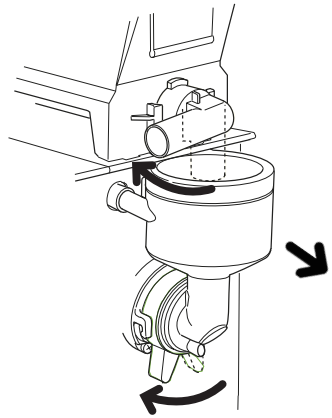

Remove all mixers by moving the canisters' spouts out of the way and rotating the ring nuts counterclockwise.

3.

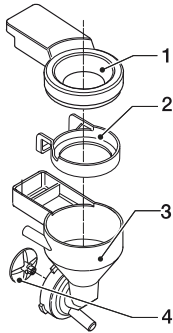

1. Powder funnel
2. Splash-guard ring
3. Water conveyer
4. Mixer impeller

Remove the mixer impellers by pulling on them. Separate all mixers' components.

4.

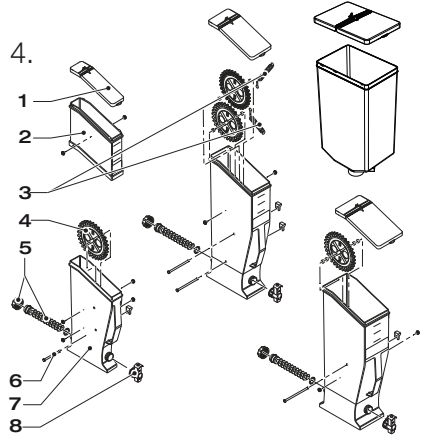

1. Canister lid
2. Canister extension (optional)
3. Spring
4. Toothed wheel
5. Worm screw
6. Pin for toothed wheel
7. Soluble canister
8. Canister elbow

Lock all canisters, then remove them from the machine. Empty them and disassemble every part.

# Monthly Cleaning Steps

5.

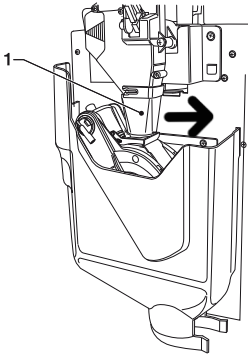

1. Coffee funnel

Remove the coffee funnel by sliding it to the right.

6.

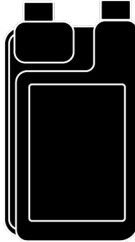

Fill a bucket (18L minimum) with 10L of hot water. Follow the instructions from the manufacturer of your food-safe alkaline formula liquid cleaner for coffee and espresso equipment.



**Water temperature in bucket must be between 140 °F and 176 °F (60 °C - 80 °C).**

7. Soak the following parts previously removed in the bucket. Brush them to remove all grime. Let soak for at least 30 minutes.

- 5 hoses
- Hoses spout part
- 3 mixers (separated)
- Canisters (separated)
- Coffee funnel



**Use cleaning brushes to remove grime from each part. Insert them in tubes, part holes and corners.**

# Monthly Cleaning Steps

8.



While parts soak in the bucket, use your food-safe cleaning and sanitizing spray, a towel and the brushes to wipe clean the other parts by following the next steps.



**IMPORTANT**  
Rinse and air dry parts  
prior to reinstall in the  
brewer.

9.

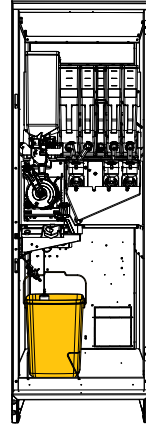

Remove the liquid waste bin, being careful to take the float out of the way. Clean it, then rinse it under hot water.

10.

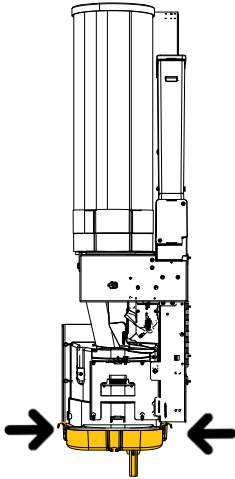

Remove the drip panel from beneath the dispensing area by unlocking it from each side. Clean, then rinse it under hot water. Air dry completely.

11.

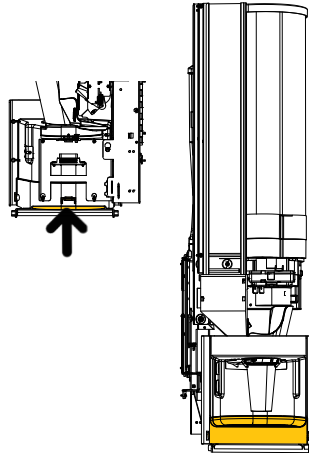

Unlock the drip tray from the back of the dispensing area, then remove it from the front. Clean, then rinse it under hot water. Air dry completely.

# Monthly Cleaning Steps

12.

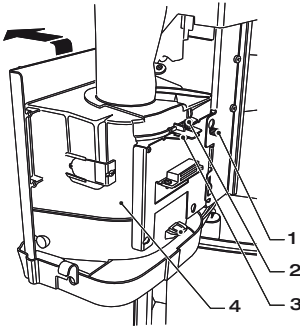

1. Dispensing compartment fastening knob
2. Cup chute fastening knob
3. Cup chute locking clip
4. Dispensing compartment

Remove the dispensing compartment from the back of the machine by unscrewing both fastening knobs and unclipping the cup chute. Clean it but pay special attention to the cup sensor area and the LED lights. Air dry completely.



## CHECKLIST

- Liquid waste bin
- Drip panel
- Drip tray
- Dispensing compartment



## IMPORTANT

**Rinse and air dry parts prior to reinstall in the brewer.**

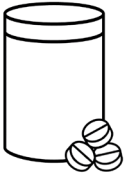

To sanitize your Z4000 coffee brewer, use an espresso machine cleaning tablet.



## IMPORTANT

**Reinstall the liquid waste bin before performing the rinse. Keep the door open during the operation to monitor the cleaning.**

13.

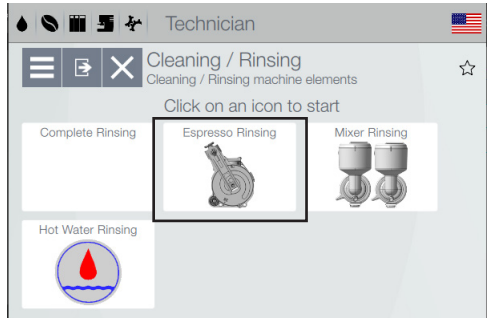

Get into service mode and go to menu 1.1 Cleaning / Rinsing. Click on the Espresso Rinsing icon then follow the steps on screen.

# Monthly Cleaning Steps

14.



After at least 30 minutes, remove all soaked parts from the bucket. Rinse and air dry completely.



**IMPORTANT**

**Rinse and air dry parts prior to reinstall in the brewer.**

15. Reinstall every part back in the brewer in the reverse order of removal.

16.

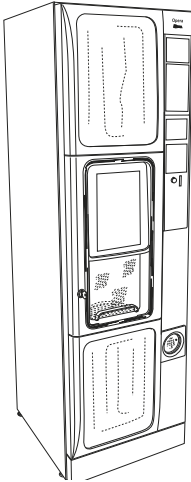

17.

Cleaning Record	
Date	Comments
_____	_____
_____	_____
_____	_____
_____	_____
_____	_____
_____	_____
_____	_____
_____	_____
_____	_____
_____	_____

Clean the exterior of the brewer and its surroundings. Do not forget to clean underneath the machine. Wipe with a towel and water. Air dry completely.

Fill the cleaning record at the back of this guide.

**Monthly cleaning steps are done.**

