

# la Radiosa

INNOVATION WITHOUT COMPROMISE

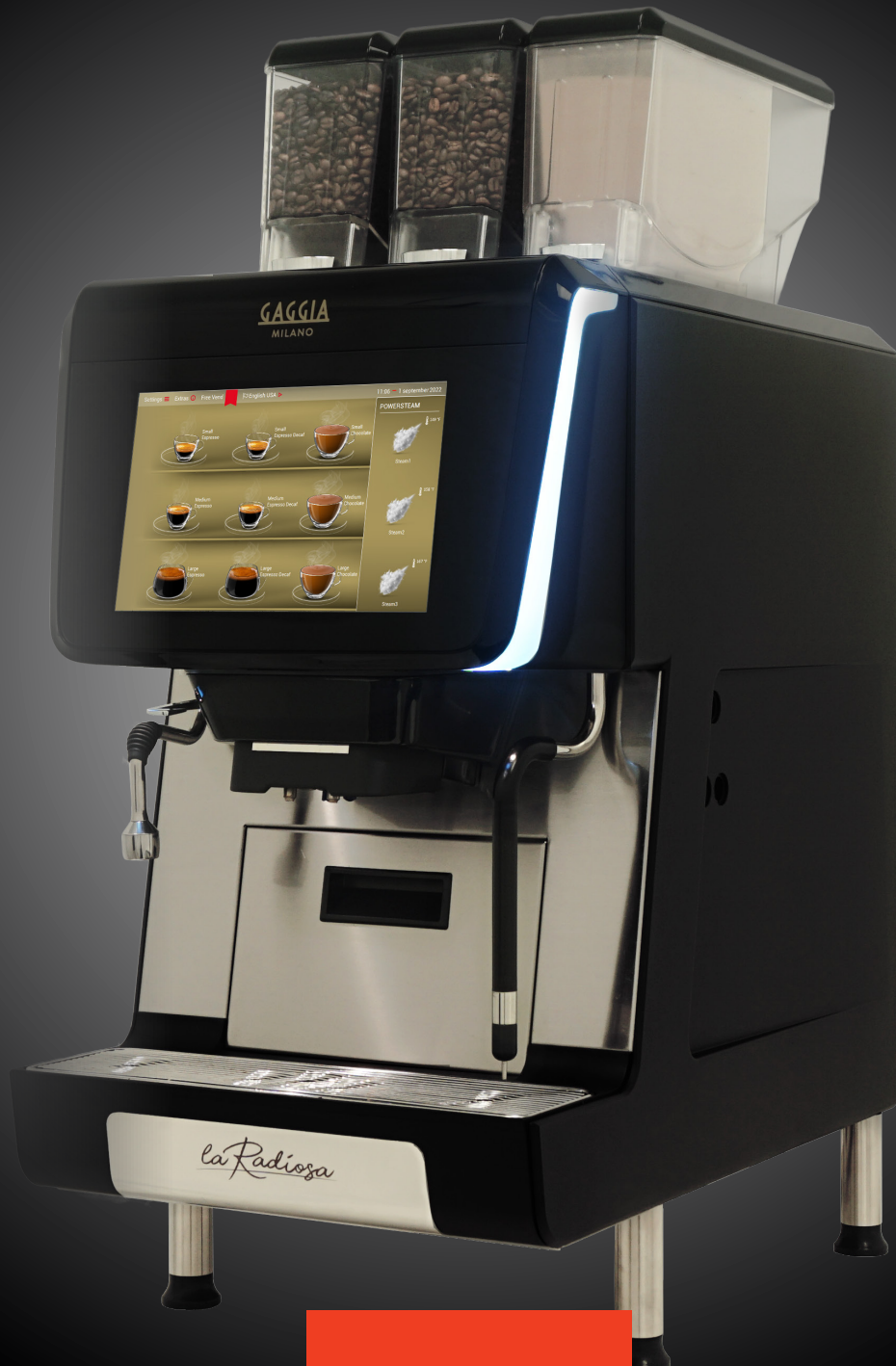

**GAGGIA**  
MILANO

2-STEP POWER STEAM HT

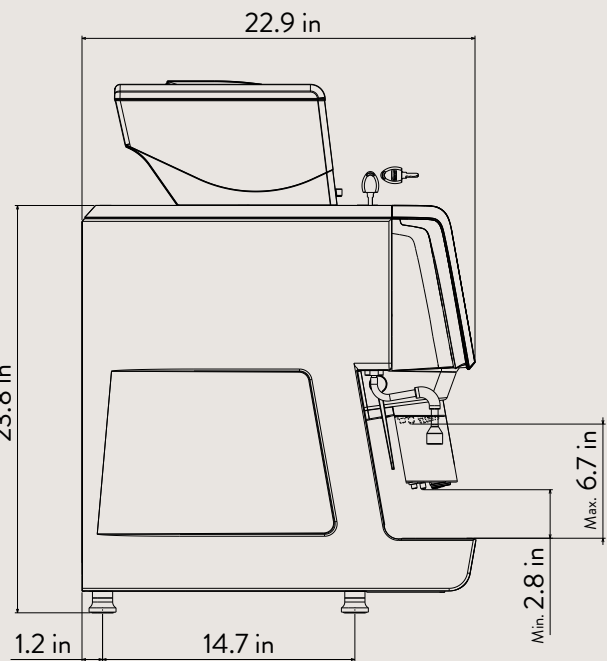
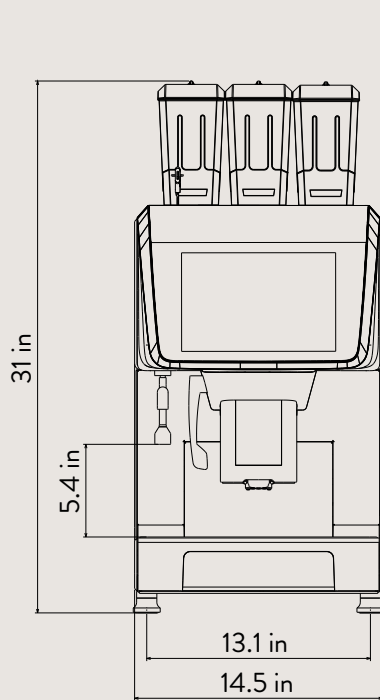

## ENHANCED PRIME MILK SYSTEM

La Radiosa has been designed to deliver high-quality, hot foamed milk-based beverages, time after time, year after year. It is possible to adjust and customize the amount of foam specified in individual recipes. La Radiosa's technology offers great advantages for consumers.

*1-STEP Model only*

## 24 V ROTARY PUMP

La Radiosa has a 24 V rotary pump with adjustable flow for variable drink densities.

This technology allows you to create unique coffee profiles. Similarly, the density of soluble drinks can be adjusted, according to your taste.





**GAGGIA**  
MILANO



## EASY CLEANING

La Radiosa was designed with the aim of creating an elegant and at the same time functional product. The automatic rinsing cycles with hot water of both milk and coffee circuits after each dispensing ensures maximum hygiene.

The touch screen and the external surfaces of the machine are easy to clean and desinfect.

## Z4000 iX BREW GROUP

Innovative Z4000 iX brew group, which boasts a heated stainless-steel chamber that ensures better stability, in terms of both temperature and quality perception. Quality offered by La radiosa remains consistent, from the first coffee of the day to the last.

This brewing unit allows you to offer a wider selection of drinks on your menu. The large capacity of its 21 g espresso brew group will never cease to amaze you.



**GAGGIA**  
MILANO



# la Radiosa

## UNRELENTING INNOVATION



More Info



The first thing you'll notice about this new machine from Gaggia Milano is its eye-catching design, centred on its door, which is surrounded by RGB LEDs. In addition to its compact dimensions, La Radiosa offers great flexibility.

### HIGHLIGHTS

- Innovative Z4000 iX 21g espresso brew group
- 2 whole bean & 1 soluble ingredient
- Cool Touch and non-sticky steam wand
- Simultaneous dispensing of coffee and steam
- Fully customizable touch screen

### FEATURES

- 10" screen with dual touch zone
- Dual boilers: 0.8 L for coffee & 1.6 L for steam
- Dual grinders, one per hopper
- Stainless steel brew chamber
- LED lights with a choice of 256 colors
- Compatible with payment systems
- 24V rotary pump with adjustable flow for variable drink densities
- Small footprint at 14.5 inches wide
- Heated brew chamber for greater consistency
- Adjustable nozzle height from 3.0 in to 6.6 in

## 1-STEP PRIME MILK

### SPECIFICATIONS

- Prime Milk – Automatic milk froth to perfection in one simple step
- Auto Steam – Temperature controlled steam wand with 3 temperature presets
- Easy complete cleaning management features

## 2-STEP POWER STEAM HT

### SPECIFICATIONS

- 2 steps milk frothing system
- Ultra performant Power Steam HT steam wand:
  - Air injection and temperature control
  - Automatic shut off with 3 temperature presets
  - Set from 0 to 100% of foam for each milk beverage

### TECHNICAL SPECIFICATIONS (BOTH MODELS)

#### DIMENSIONS

Width	14.5 in
Height	31.0 in
Height with NSF/ANSI 4 legs	33.6 in
Depth	23.1 in
Weight	97.0 lb

#### CAPACITY & OTHER SPECIFICATIONS

Coffee beans container	2 x 2.6 lb
Chocolate powder container	3.9 lb
Brew group	Up to 21g
Espresso brewing pressure	9 bar
Waste bin drawer capacity	50 drinks

#### ELECTRICAL SPECIFICATIONS

Voltage and frequency	208-240 V / 60 Hz
Plug	L6-30P
Maximum absorbed power	5800 W

#### HYDRAULIC SPECIFICATIONS

Coffee boiler capacity	0.8 L / 0.2 US gal
Steam boiler capacity	1.6 L / 0.4 US gal
Water pump flow	80.0 L / 21.1 US gal per hour



**GAGGIA**  
MILANO

**EVOCA**  
GROUP

**EVOCA**  
GROUP

Evoca North America  
2355, avenue Dalton, Québec (Québec) G1P 3S3, Canada  
T: 800-561-6162 - F: 800-463-2739  
www.evocagroupna.com

Evoca Group Headquarters  
Via Roma, 24, 24030 Valbrembo BG Italy  
T: +39 035606111 - F: +39 095606560  
www.evocagroup.com